

# Big Science Business forum 2022

**ESRF**

*European Synchrotron Radiation Facility*

## *Overview on mechanical manufacturing at the ESRF*

**Big Science  
Business  
Forum  
2022**





- **ESRF's roadmap**
- **Focus on mechanical topics**
- **Mechanical manufacturing for the ESRF**



**Implementation of the Extremely Brilliant Source Project at the ESRF**  
Plenary Session I  
MARTINEZ CRIADO Gema / Director of research

**Procurement Process at the ESRF => See BSBF / Procurement Handbook**

# MEDIUM & LONG TERM ROADMAP

2022	2023	2024	2025	2026	2027	2028	2029
------	------	------	------	------	------	------	------

**Completion of the ESRF-EBS programme (2022-2023)**

**Regular beamlines refurbishment**

**New EBS beamlines implementation**

**Improvement of the operation performance of the accelerator complex  
(linac, injection cell, booster, EBS storage ring & Insertion Devices)**



## Focus on Mechanical topic

New insertion devices + small gaps

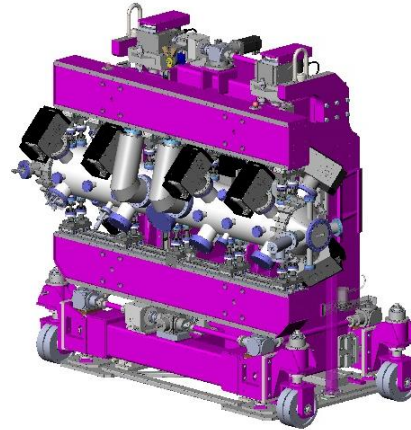
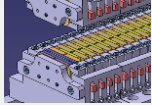

- Large metallic welded frames
- High rigidity
- Motorized
- Completely assembled

Four new beamlines fully optimized for EBS

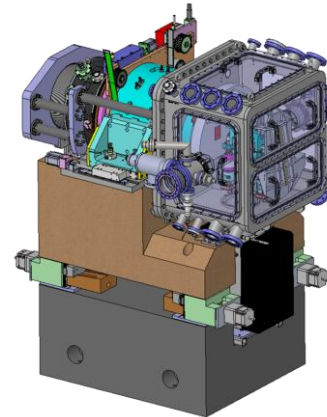
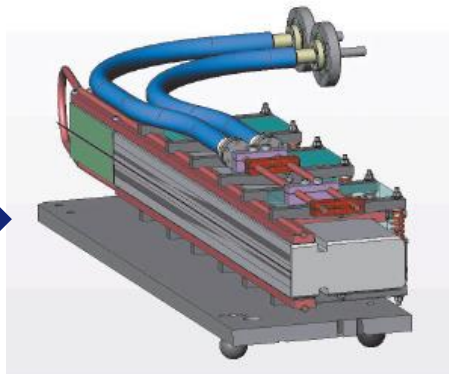

- High precision mechanic systems
- High rigidity, **high stability**
- High thermal load / LN2 cooling
- UHV
- Nano positioning

Refurbishment Programme  
Several beamlines



- Huge diversity of mechanical components
- From simple to very complex systems
- From single parts to complete assemblies





## Manufacturing of individual parts

- Unitary part only
- Very few series of pieces

- Conventional machining
- Electro-erosion
- Mechanical welded assy
- UHV manufacturing
- Welding
- Brazing
- Inspection report
- *Additive manufacturing*

## Manufacturing of comprehensive instrument

- Machining of all parts
- Possibility of **pre-assembly**

## Assembly of instrument

- Machining of all parts
- Purchase of commercial parts
- **Full Assembly**
- Preliminary tests
- Functional tests

# MECHANICAL TOPIC - BREAKDOWN BY DIFFERENT TECHNIQUES

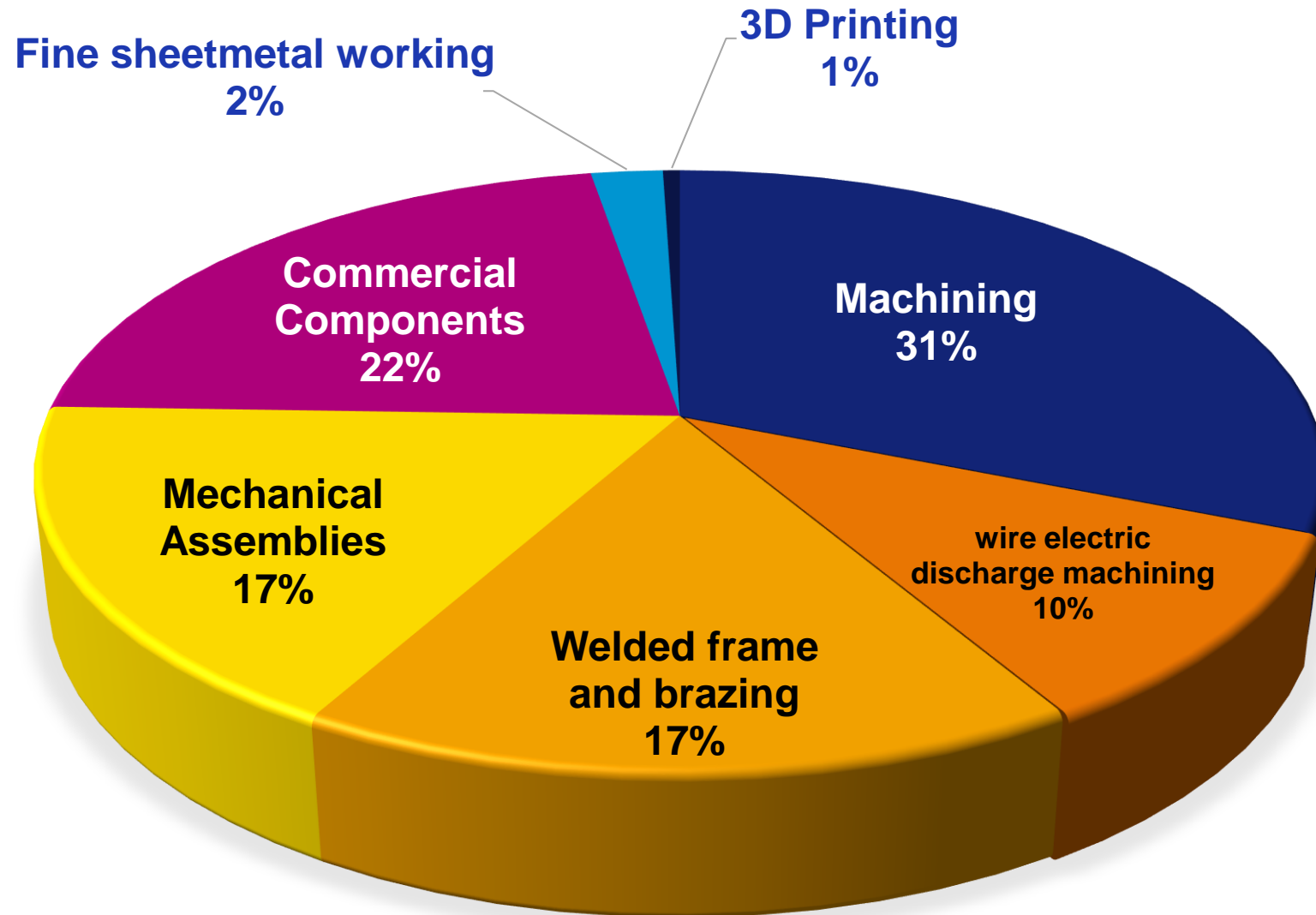

Year 2021  
Total amount ~1.5M€

Year 2022  
Total amount envisaged  
~1M€

Year 2023  
Total amount envisaged  
~1.5M€

## Machining of individual parts

- Unitary part only
- Very few series of pieces

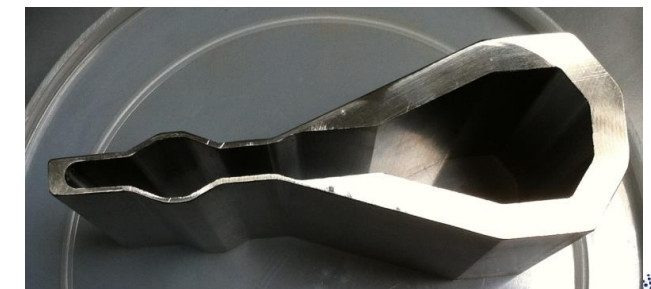
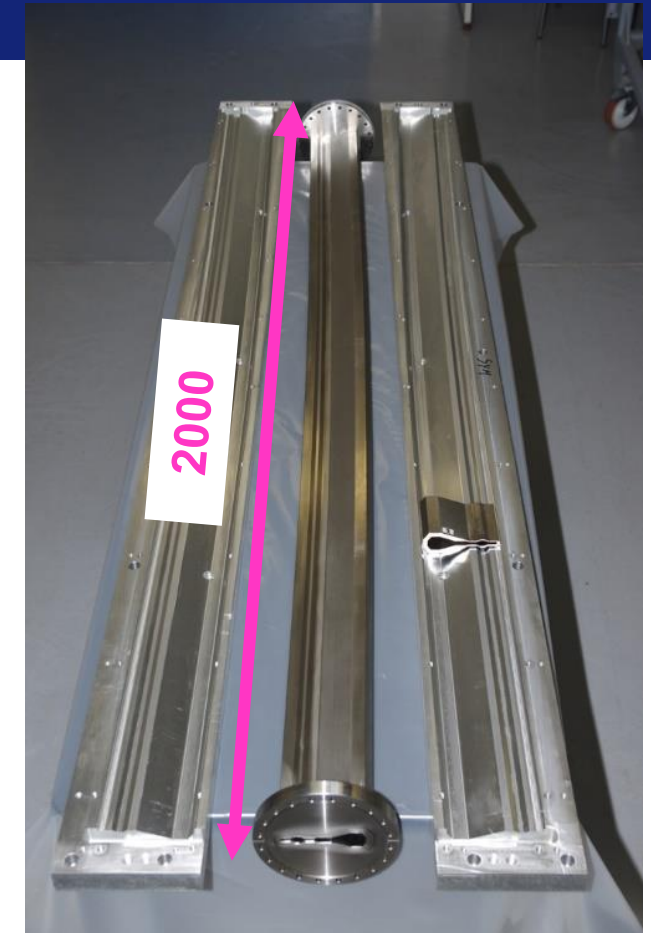
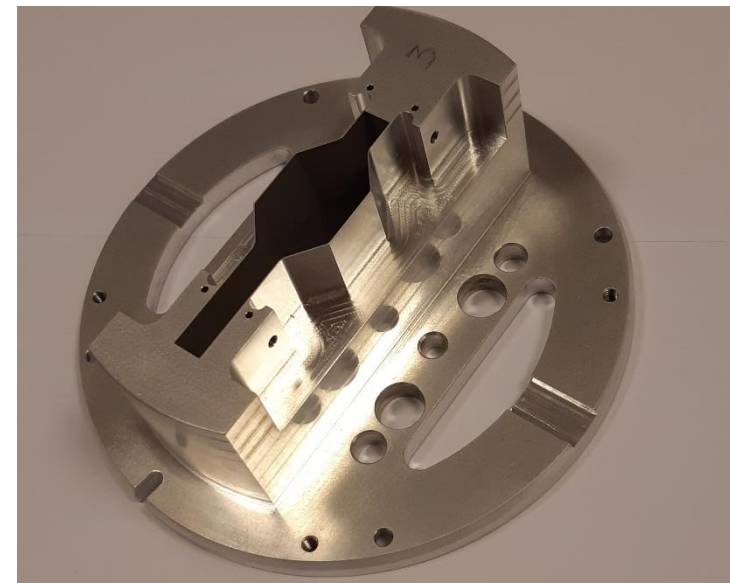
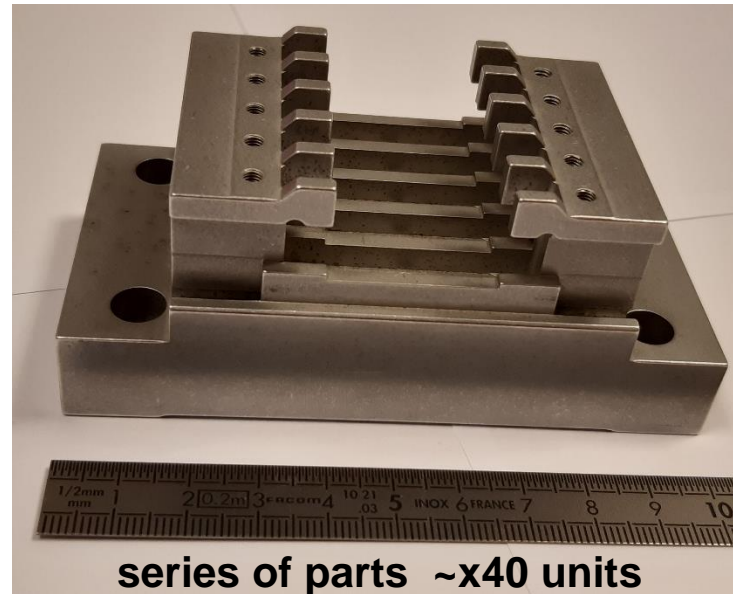

- Conventional machining
- Electro-erosion
- Mechanical welded assy
- UHV manufacturing
- Welding
- Brazing
- Inspection report
- *Additive manufacturing*



UHV thermal absorber

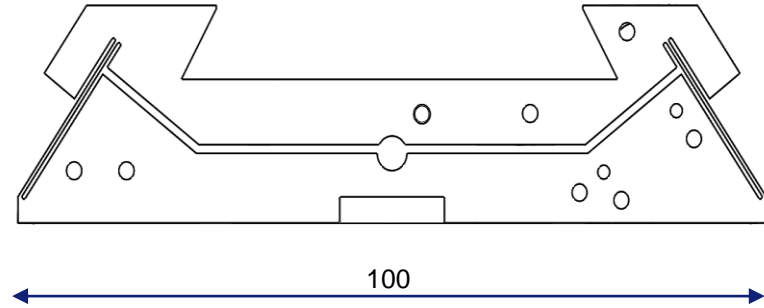

RF finger

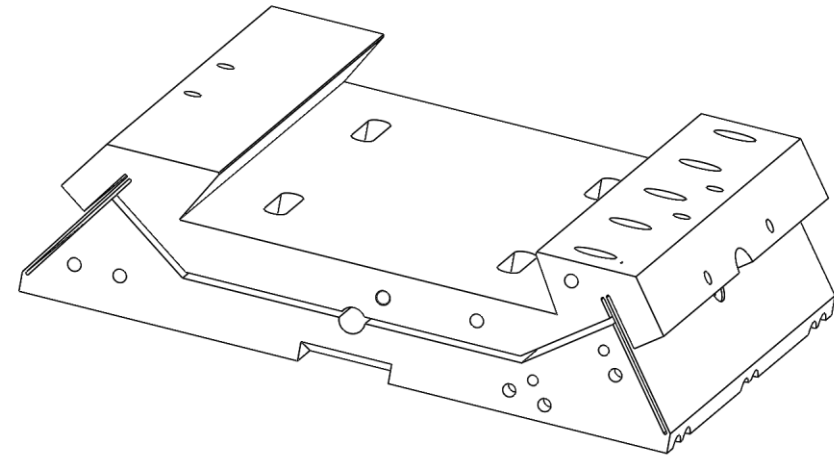
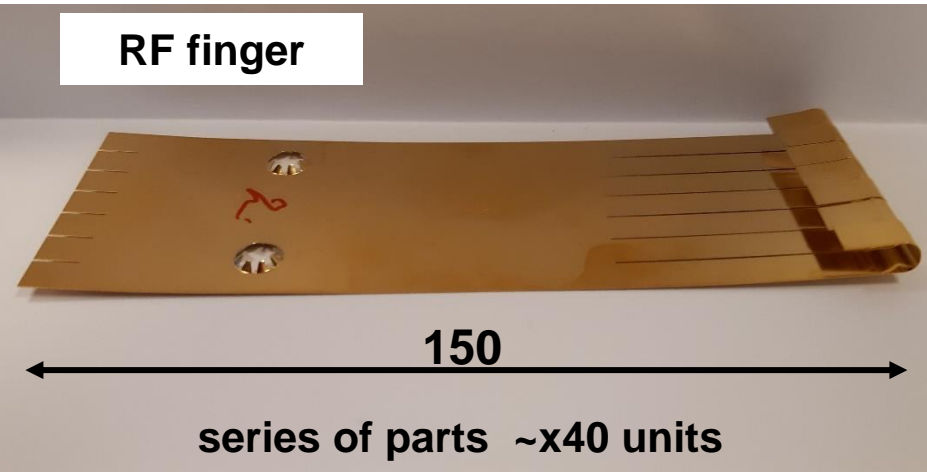

Machining of individual parts  
~400k€ / year

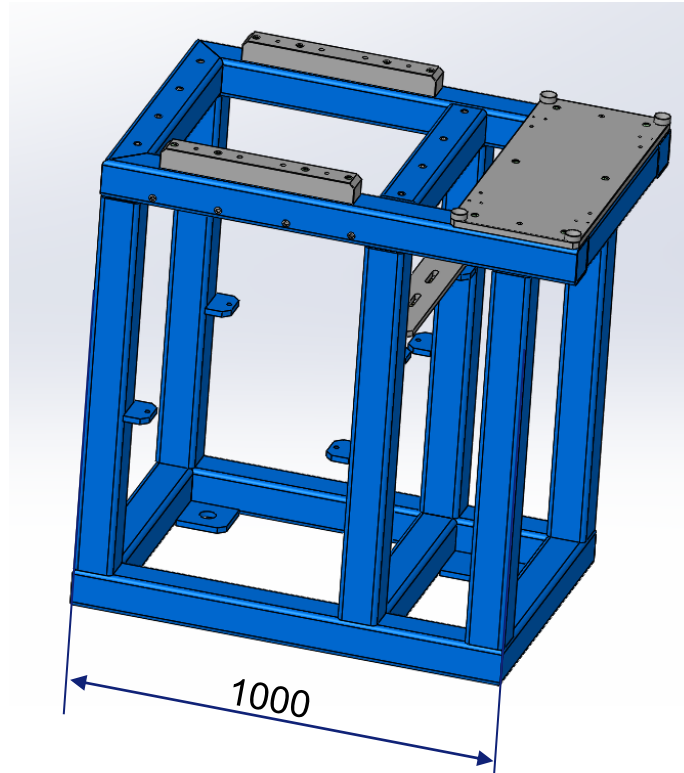
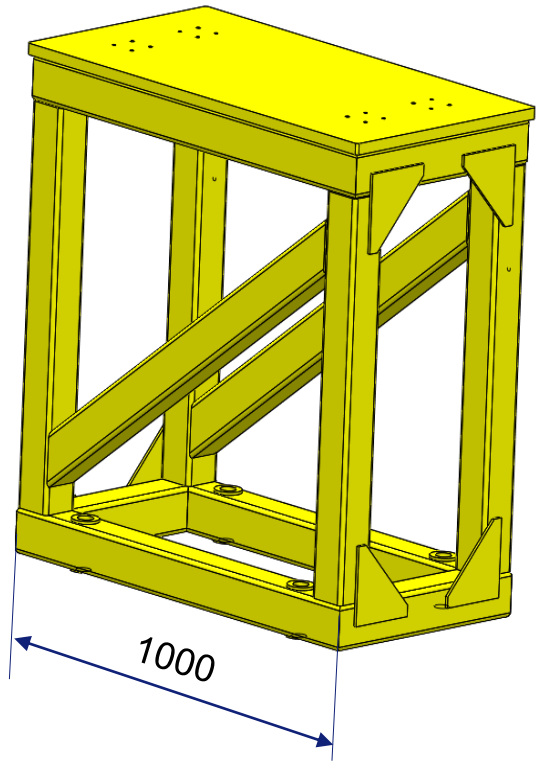

machined surfaces  
with geometrical tolerances



- Machining of all parts
- Possibility of pre-assembly

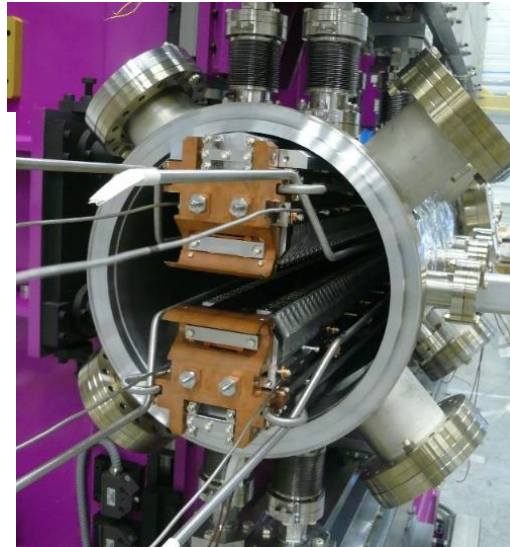
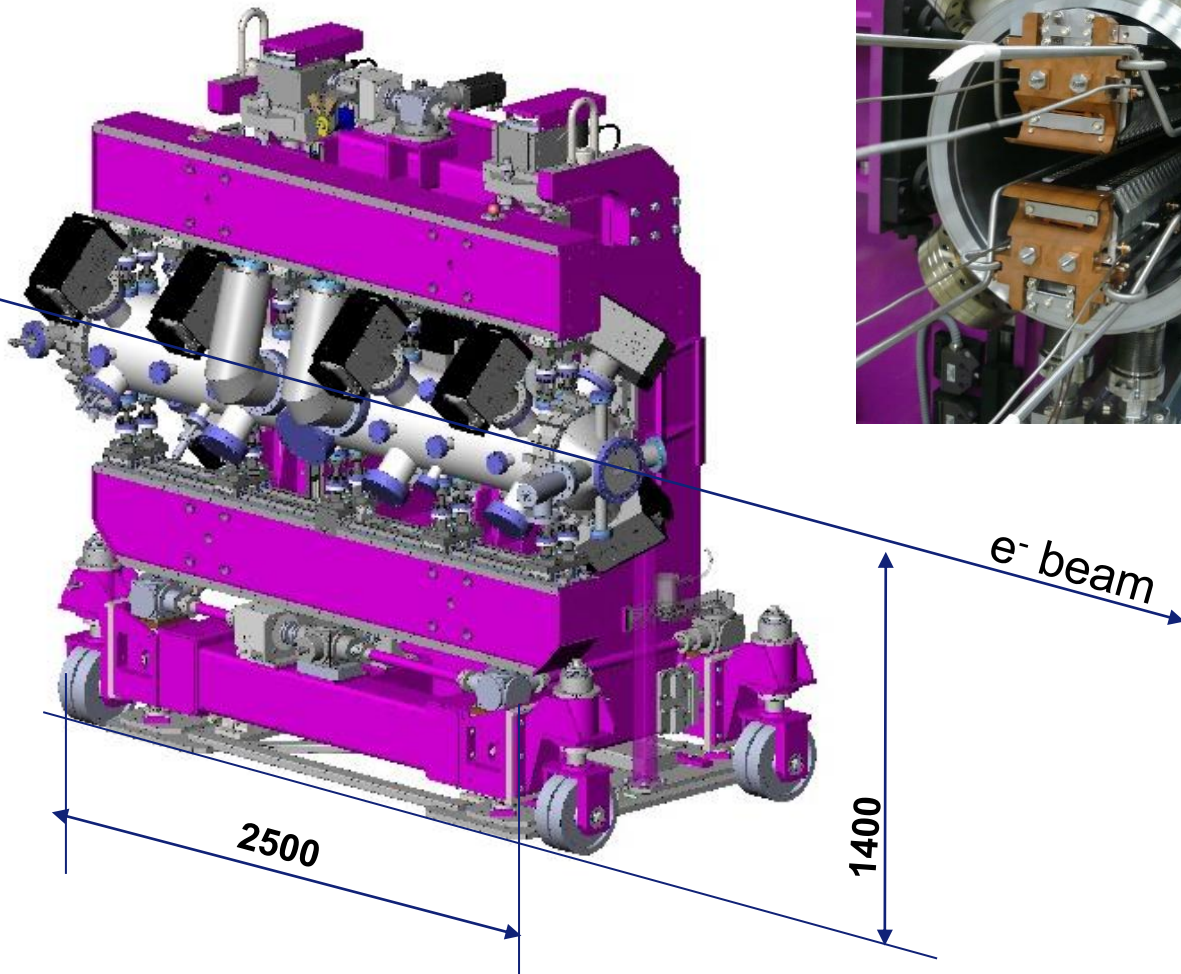

## In vacuum undulators

from ESRF drawings and technical specifications

Will be split in several Call For Tenders:

1. External motion systems and support frame
2. Vacuum chambers and internal parts
3. High precision machined parts

Capabilities required:

For 1. Welded-machined “heavy” precision motion systems.

For 2.

- Stainless steel welding
- Vacuum brazing
- Cleaning
- Vacuum testing



# Manufacturing of comprehensive instrument

from ESRF manufacturing drawings and technical specifications

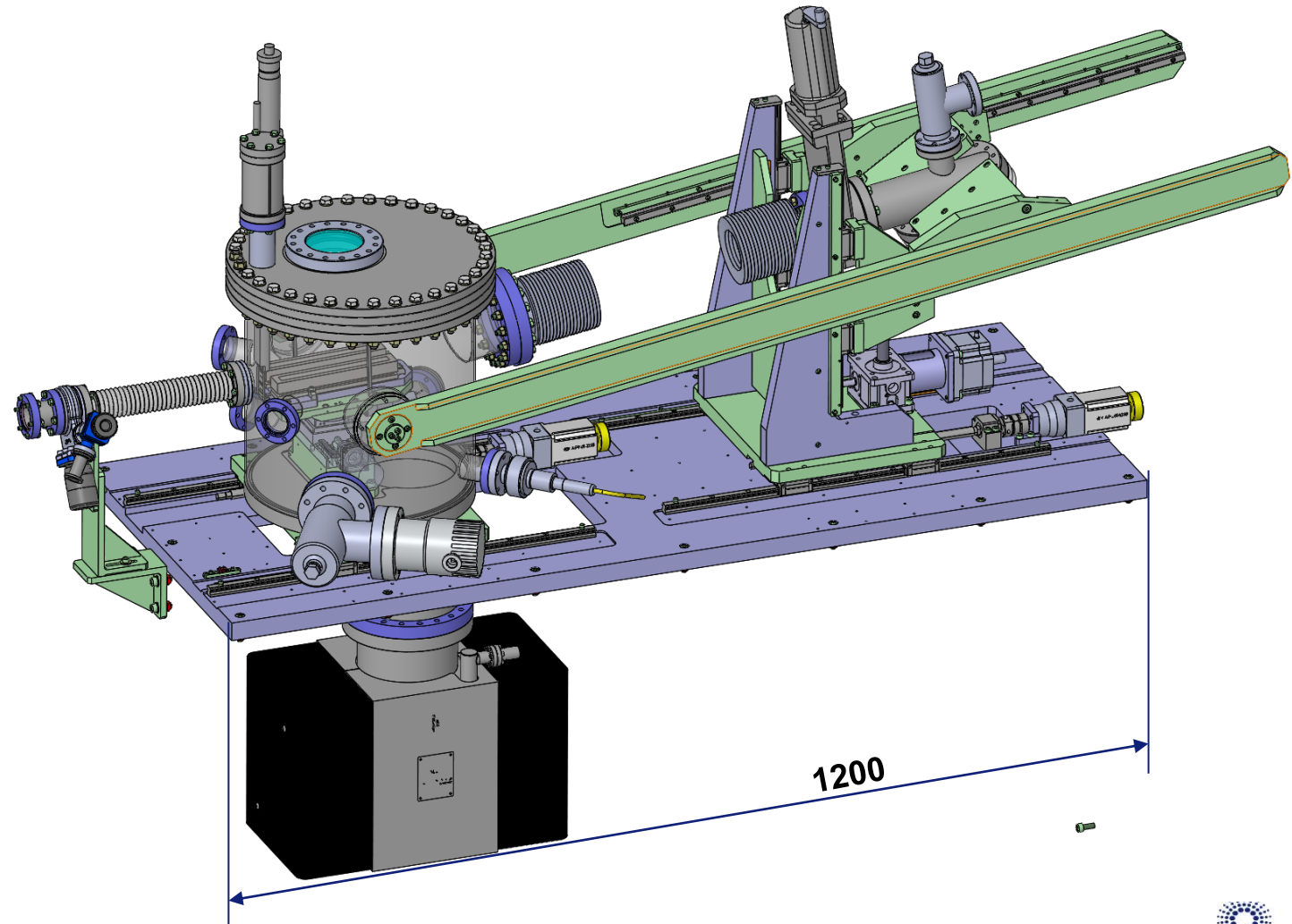
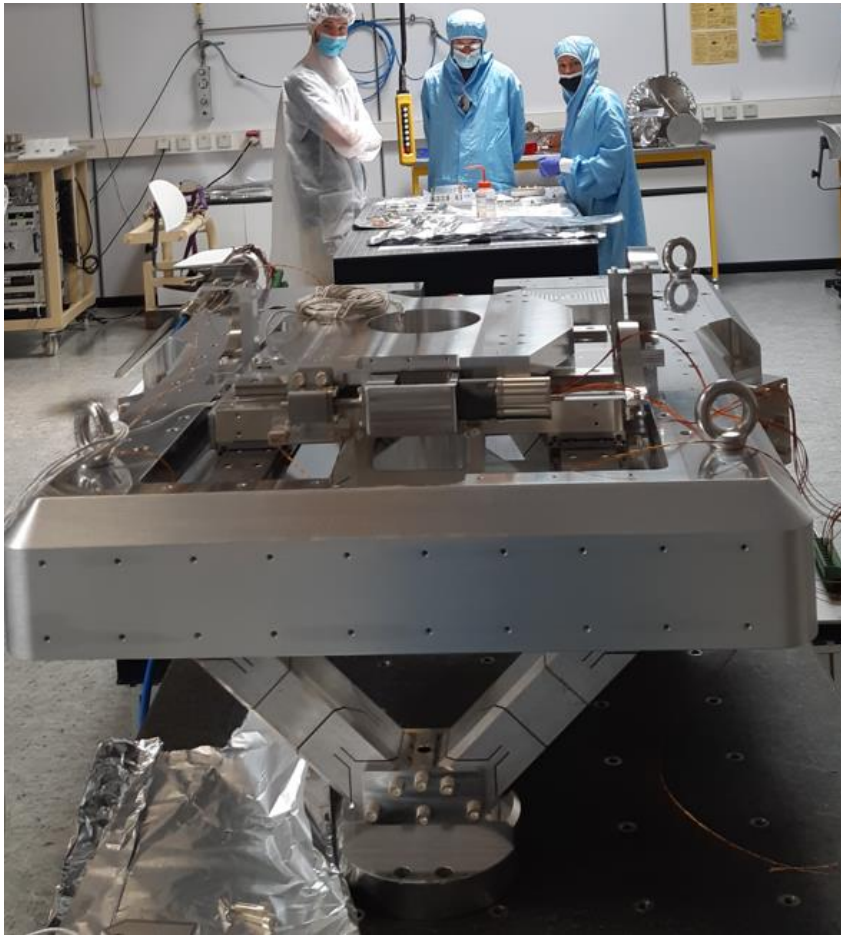



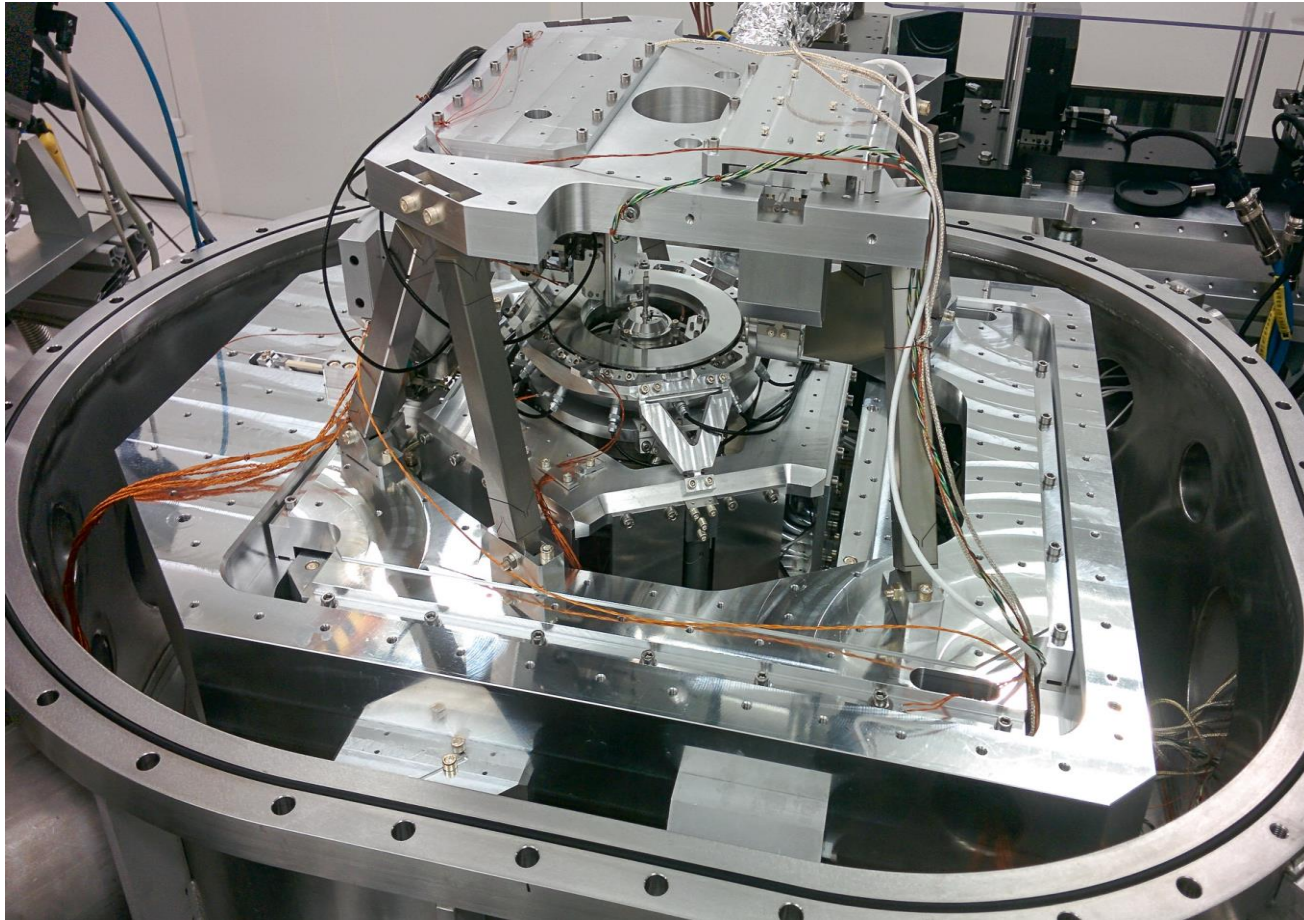

ID16A-NI end station

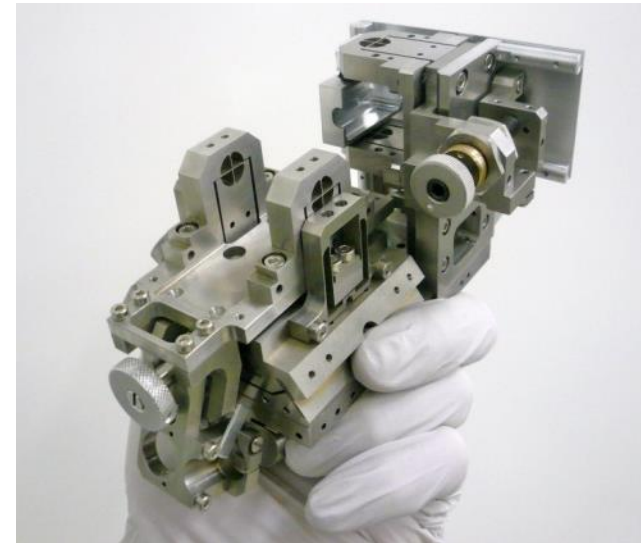
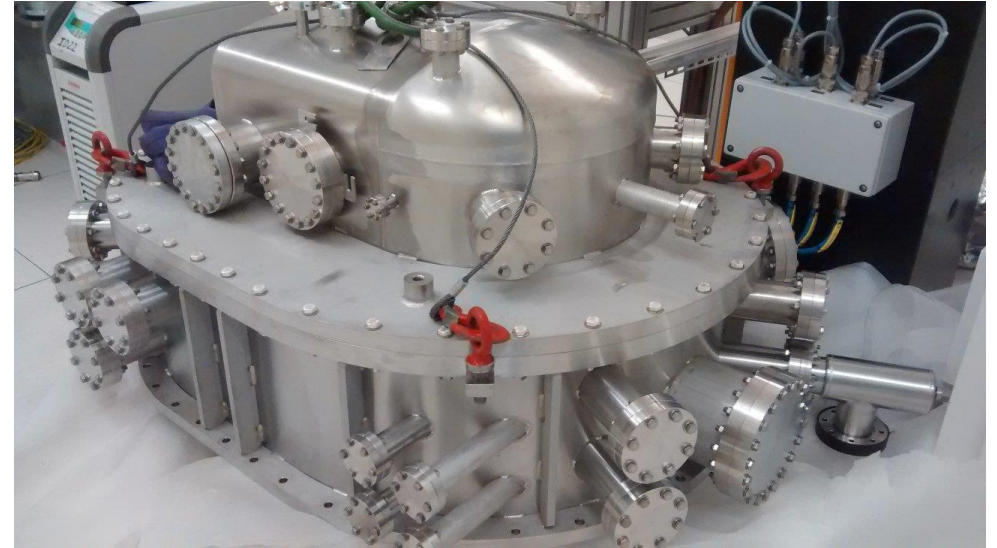

## BM18 Slits

CFT to be launched soon for 4 units.

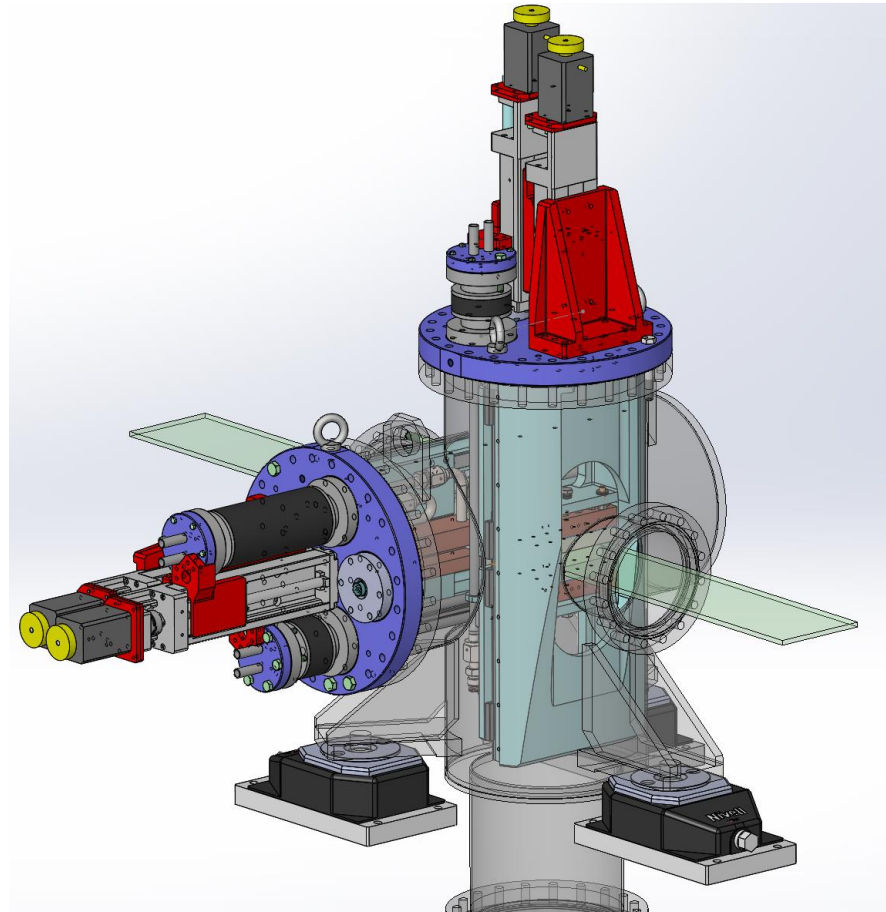
**Scope of supply:**

- Fabrication
- Assembly
- Tests

**Capabilities required:**

- Precision machining
- Stainless steel welding
- Vacuum brazing
- Cleaning
- Assembly
- Vacuum testing
- High precision motion tests

## BM18 Attenuators

CFT to be launched soon for 15 axis and vacuum chambers.

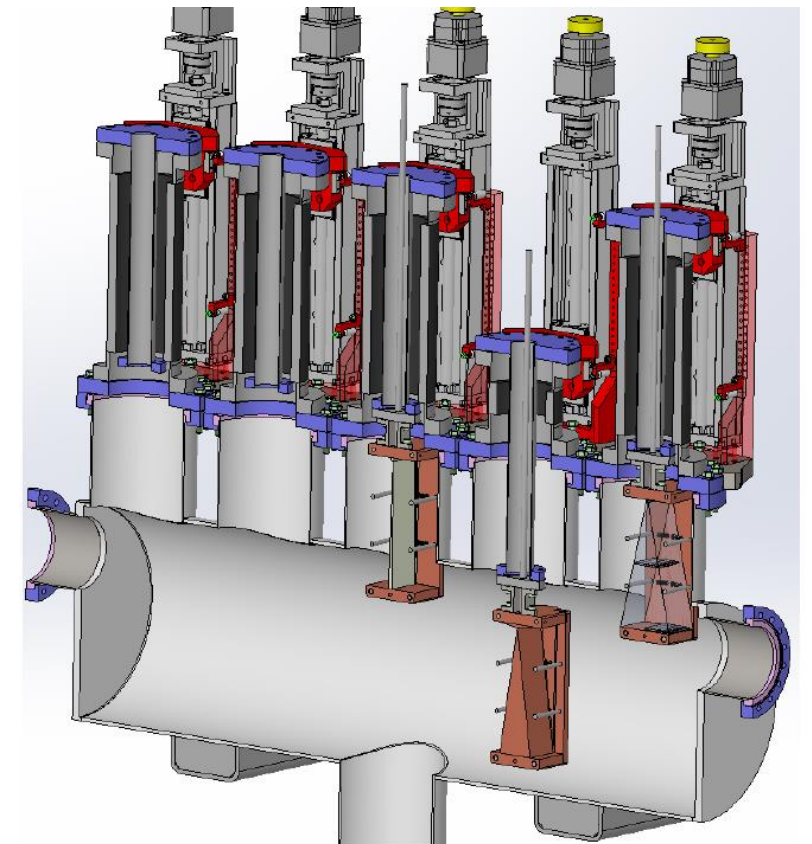



## Assembly of instruments

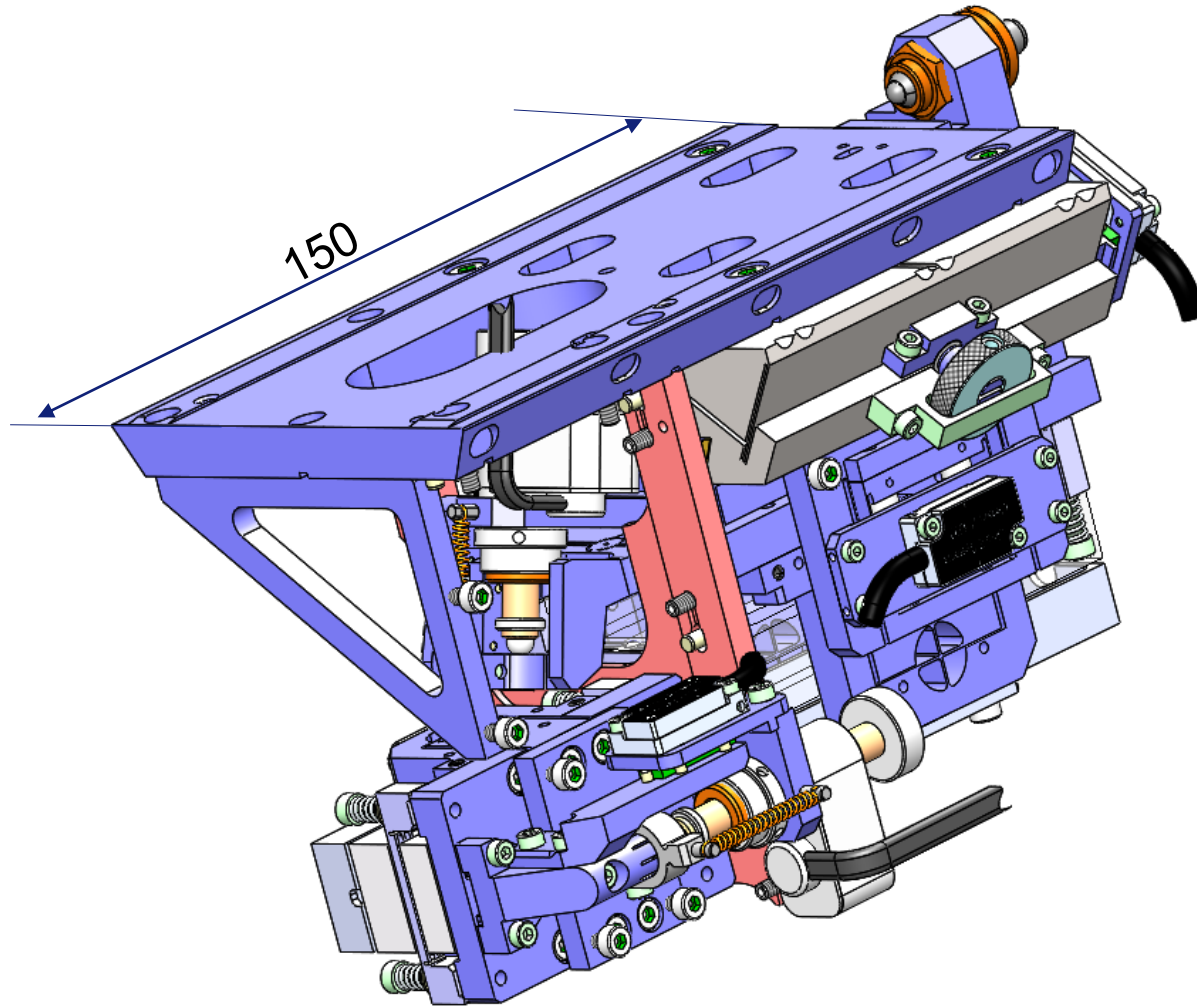

- Machining of all parts
- Purchase of commercial parts
- **Full Assembly**
- Preliminary tests
- Functional tests

# Assembly of instruments

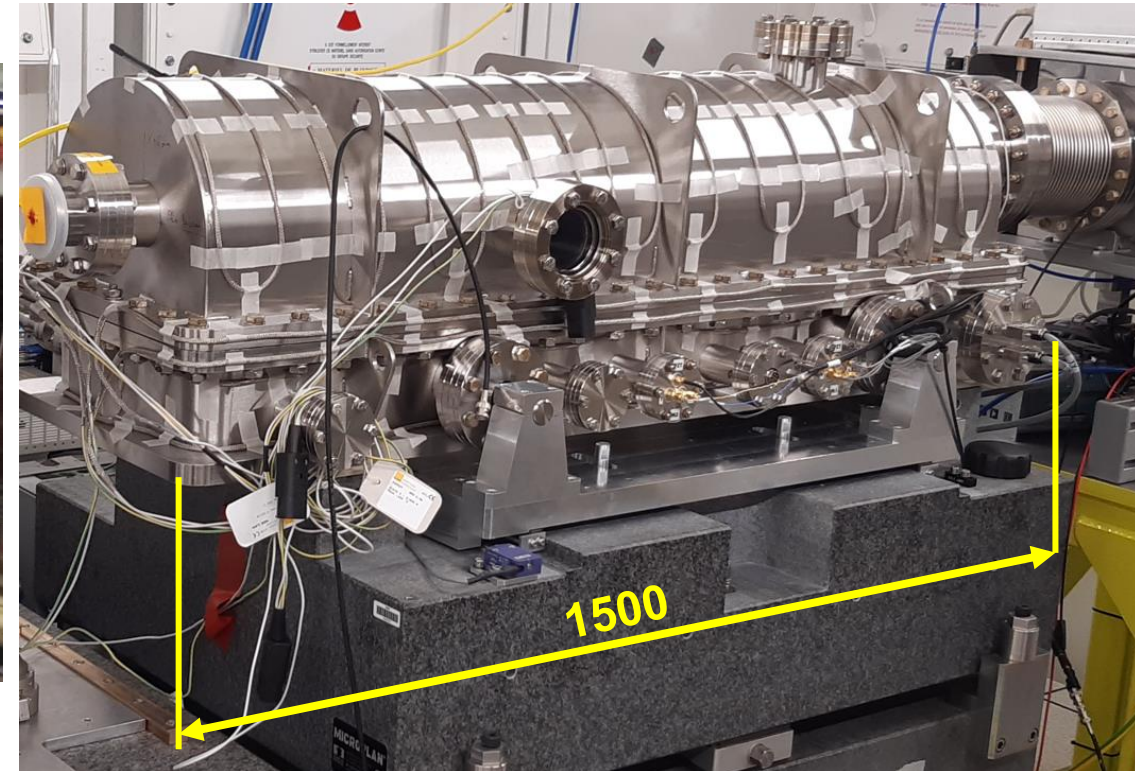
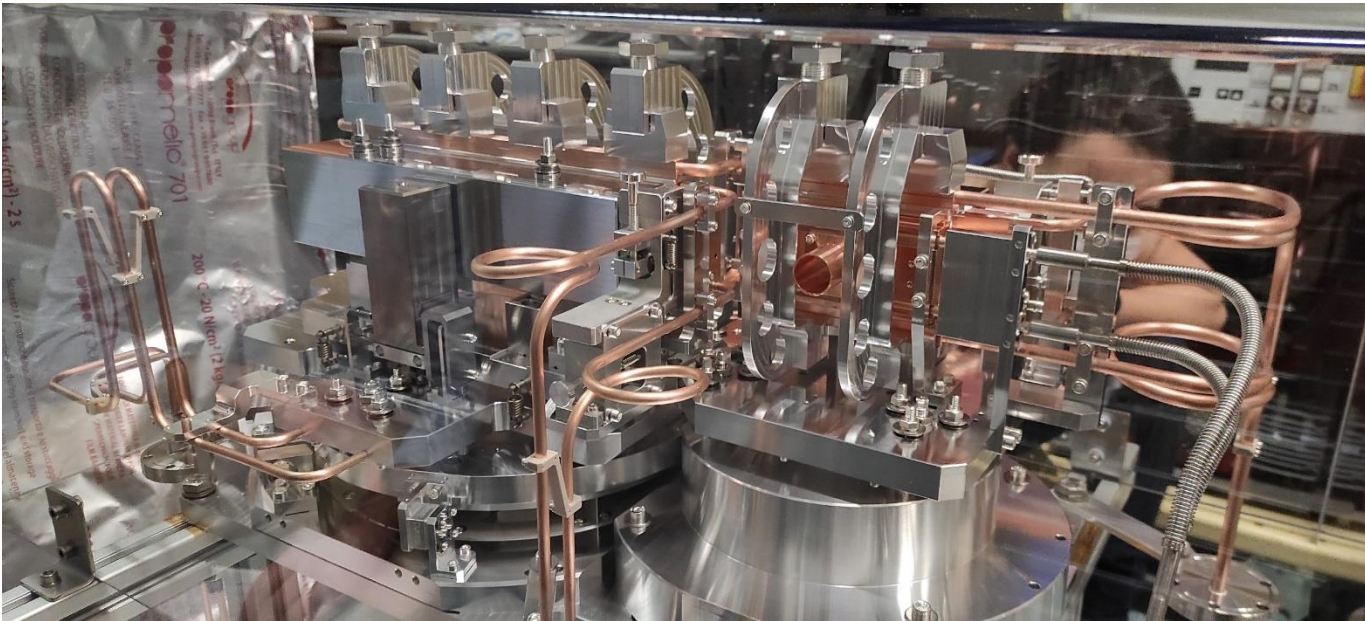

## CONTACT LIST

### Mechanics

- Instrumentation Support and Development / Mechanical Engineering
- Head of group: **MARION Philippe**  
*marion@esrf.fr*
- Head of Procurement Unit: **DALLE Didier**  
*dalle@esrf.fr*





# Thank you for your attention

## Big Science Business Forum 2022

PIONEERING SYNCHROTRON SCIENCE

